

## 10.1" Rugged Tablet with Intel® Alder Lake N Series Processor



### Features

- Intel Alder-Lake series with Low power consumption with fan-less design
- 10.1" FHD display (1920 x 1200 resolution / 500 nits / 30,000 hrs) optical clear Adhesive with Anti-fingerprint / rugged coming gorilla glass P-Cap touch
- Dual-main battery with Hot-swap design & up to 8 hrs operating
- Multi-peripherals & accessories (Wi-Fi6E+BT 5.2 / 2D barcode scanner / 2D camera / 3D camera / LTE+GNSS / LAN / COM / SD card / smart card reader / fingerprint reader / hand strap / neck strap / stylus / cradle / vehicle cradle... etc)
- IP65 rating & drop test 1.5m design (MIL-810H standard)
- Wide-ranged temperature & light weight 1.0 kg (tablet only)
- Integrated with LIPS 3D camera for logistics dimension measurement application

### Highlights

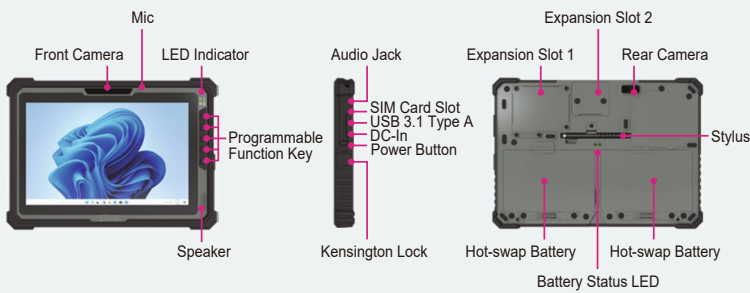

### Dimensions

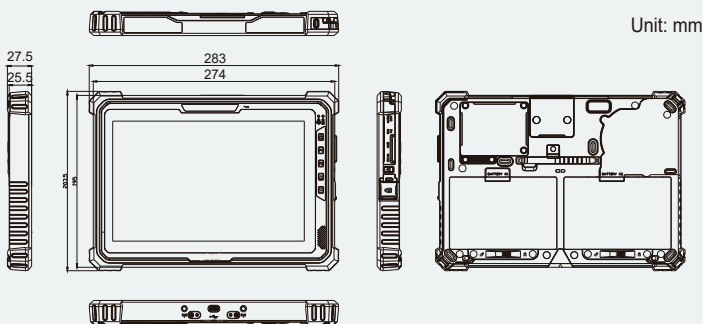

### Specifications

Tablet Specifications	
CPU Support	Intel® Alder Lake-N processor N50 Intel® Alder Lake-N processor N200
Display	10.1" 1920 x 1200
Brightness	500 cd/m2
O.S. Support	Windows 11 IoT Enterprise
Memory	LPDDR5 8GB or 16GB
Storage	1 x M.2 Nvme SSD (up to 1TB)
Speaker	2W
Stylus	Yes (optional)
Power Input	DC jack 19V, USB Type-C power delivery 20V
G-Sensor	Yes
Ambient Light Sensor	Yes
Vibrator	Yes
TPM	TPM 2.0
Dimensions (W x H x D)	275 x 194.5 x 21 mm
Weight	1080 g (tablet only)
Certifications	CE/FCC
Capacity	2 x Li-Ion battery (11.1V, typical 2100mAh)
WiFi + BT	802.11 ax, Bluetooth®
WWAN	4G/5G with GNSS
Barcode Scanner	2D barcode scanner (optional)
Camera	Front camera 2M pixels (optional, Windows hello camera) Rear camera 8M pixels 3D camera for dimension measurement application (optional)
Fingerprint Reader	Fingerprint reader (optional)
Smart Card Reader	Smart card reader (optional)
Tablet I/O Ports	
SD Card	1 x Micro SD (optional)
USB	1 x USB 3.0 type A 1 x USB type-C (with display port & power delivery) 1 x USB 3.0 type A (optional)
Expansion Slots	Expansion Slot 1 (2D barcode, COM port, USB 3.0 Type-A, SD card, LAN port) (optional) Expansion Slot 2 (smart card reader, fingerprint, 3D dimensioner camera) (optional)
Multi-Function Key	6 x Buttons (Windows, power, function key 1, function key 2, volume up, volume down) (programmable)
SIM Card	2 x Micro SIM-card slot
Audio Jack	1 x Headset (headphone out / mic-in combo)
DC Jack	1 x DC 19V
Environment	
Operation Temp.	-10°C~50°C (AC) (14°F~122°F) -10°C~50°C (battery) (14°F~122°F)
Storage Temp.	-20°C~60°C (-4°F~140°F)
Humidity	Operation humidity 10%~90% Storage humidity 10%~95%
Vibration	MIL-STD-810H
Dust & Water Resistance	IP65
Drop	150cm (MIL-STD-810H)

### Application

- Automation
- Banking
- Warehouse
- Retail
- Transportation
- Asset Tracking
- Food Service
- Hospitality
- Power Patrol Inspection
- Logistics
- Manufacturing

